

PRO LINE

CAV JB-30/CAV JB-35

On-ground Full-rise Double Scissor Lift



3000 | KG

3500 | KG



Overall dimension

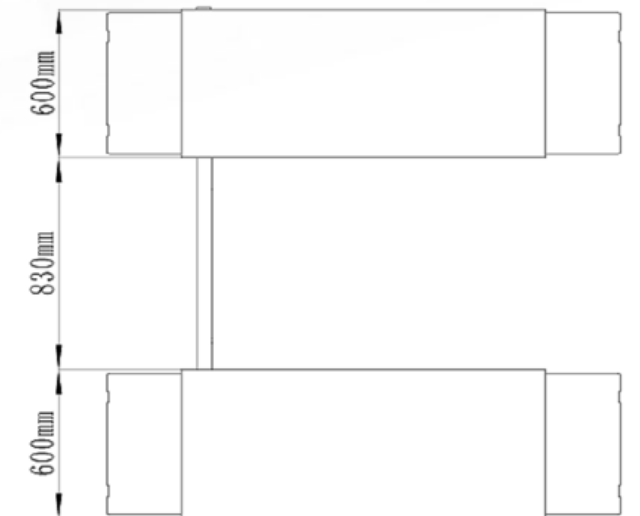
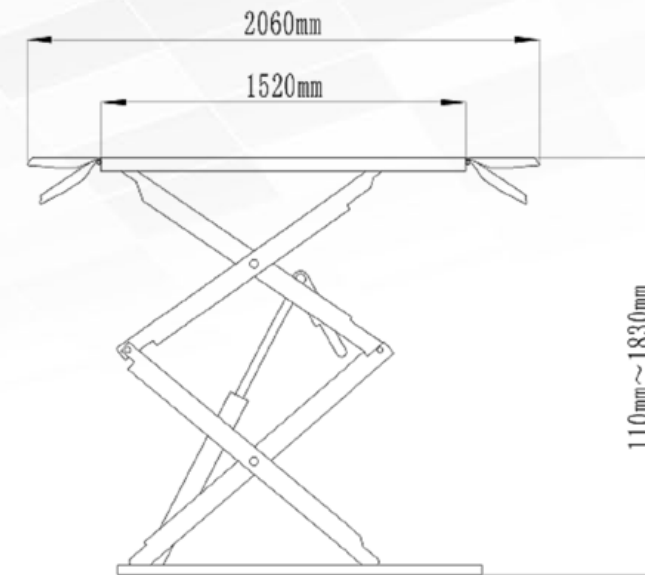

Highlights

- Perfect lift for painting jobs and bodywork, brakes and tire service
- High-precision manufacturing by laser cutting and robotic welding
- Robust and less sensitive hydraulic drive, almost maintenance-free
- Suitable for surface mounting installation
- The double master and slave system ensures an even lifting and lowering of the scissors which permanently controls the synchronization of the lift
- With mechanical rocker arm system, in order to lift with full power
- Low drive over height and runways with lockable drive-on ramps
- Lifting and lowering with push button control
- Hydraulic double locking system for lowering (neither safety locking-system nor compressed air necessary), emergency lowering system for lowering in case of power failure, CE stop and signal sound
- Powder-coated lift
- Each lift passes the test of 115% dynamic load and 150% static load, safe and reliable

Technical

	CAV JB-30	CAV JB-35
Capacity	3000kg	3500kg
Max.Lifting height	1850mm	1850mm
Min.height	110mm	110mm
Platform length	1520mm-2060mm	1520mm-2060mm
Lifting time	45-50s	45-50s
Power of motor	2.2kW	2.2kW